

2RMLG

Operating Recommendations

SAFETY

The commissioning and maintenance of protection equipment should only be carried out by skilled personnel trained in protective relay operation and capable of observing all the necessary safety precautions and regulations appropriate to the equipment and also the associated primary plant.

Equipment should be isolated from auxiliary supplies and the circuit breaker trip circuit prior to commencing any work.

UNPACKING, HANDLING & STORAGE

On receipt unpack the equipment and inspect for any obvious damage. It is not normally necessary to remove it from its polythene bag unless some damage is suspected or if it is required for immediate use.

If damage has been sustained a claim should immediately be made against the carrier, also inform Reyrolle Protection and the nearest Reyrolle agent.

When not immediately required return the equipment to its carton and store in a clean, dry, place.

DESCRIPTION

The range of 2RMLG Test Blocks, housed within an Epsilon enclosure, offers facilities for monitoring and secondary injection testing of power system protection schemes in conjunction with the MMLB 01 multi-fingered test plug. The MMLB 02 is a single fingered test plug available for monitoring current flow in individual circuits connected through the test block.

The 2RMLG Test Block has 14 pairs of spring loaded contacts which are linked to a terminal block positioned at the rear of the enclosure.

The 2RMLG07 is coded to only accept the MMLB07 Test Plug which has connection terminals 21, 23, 25 & 27, internally – For typical application see Fig 4.

The 2RMLG08 is coded to only accept the 2RMLB08 Test Plug which has internal pairs 1&3, 5&7, 9&11 and 15&17 shorted together internally – For typical applications see Figs 5, 6, 7 & 8.

Each pair of contacts is normally closed completing the circuit through the test block when the associated protection equipment is in use.

For testing purposes the test block can be assessed by removing the front cover. The 2RMLG 01 has a metallic probe attached to the front cover assembly which when withdrawn open circuits the 2 contacts at position 13 and 14.

The main dc auxiliary supply to the protection scheme or relay can be wired to this circuit to prevent inadvertent

tripping of the protection circuit after removal of the cover and during the test procedure.

The 2RMLG 02/07/08 do not include the above facility and contacts 13 and 14 are normally closed. These contacts must not be used for current circuits, as the relevant contact finger on the MMLB 01 test plug is shorter in this position.

The short test finger in position 13-14 on the MMLB 01 will open contacts 13-14 in the test block after the other fingers have made contact in all other positions.

When the cover is removed a yellow fascia is revealed which is attached to the test block this gives a visual indication and warning that the protection scheme or relay is not in service.

The insertion of the MMLB 01 test plug into the 2RMLG assembly (as shown in figs. 1 and 2) open circuits the contact pairs. The MMLB 01 has 28 test points each position being identified by a number which corresponds with the terminations on the 2RMLG.

It is recommended that the protection scheme or relay is wired to the even numbers of the test module. To ensure the scheme wiring is routed logically it is recommended that the 2RMLG is always positioned on the right-hand side of the relay, when viewed from the front. The connections to other equipment such as CTs, VTs, and dc supplies should be made to the odd numbered terminals indicated on the 2RMLG. This will ensure that on connection of the MMLB, the sockets on the even numbered side of the test plug are the isolated relay circuits and the sockets on the odd numbered side are connected to the potentially live supplies as shown in Figure 3 & 4.

Note: It is important that the sockets in the test plug (MMLB01&02) which correspond to the current transformer secondary windings are linked prior to the test plug being inserted into the test block.

This will ensure that the current transformer secondary windings are short circuited prior to disconnection from the protection scheme or relay (as shown in Figure 3).

If the The dc auxiliary supply is to be used during testing it can be linked using the sockets in the test plug.

Operation of the contacts can be monitored by connecting the test equipment to the protection scheme or relay with the even numbered sockets of the test plug.

If a number of 2RMLG test blocks are connected to a relay it is recommended that the dc supply be routed through each of them to safeguard against inadvertent operation.

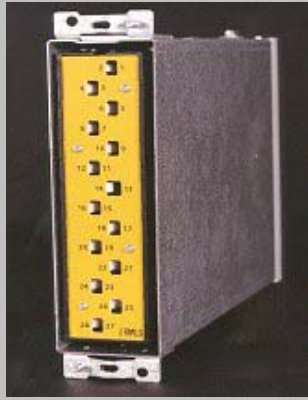

Figures 1 & 2

Single-finger Test Plug

The Single Finger Test Plug consists of two contact blades each insulated from the other and each connected to a lead, as shown in Figure 1.

This test finger is used to insert into individual test positions as shown in Figure 1 and is an alternative to the multi-fingered test plug. It is used to monitor the current in any of the circuits passing through the test module.

Note: An ammeter set at the correct range should be connected to the leads prior to the plug being inserted, especially if a CT secondary circuit is being monitored.

Mechanical Specification

The 2RMLG is a size E2 unit in the Epsilon range of enclosures.

The overall dimensions and panel fixing details are shown in Figure 9.

The rear terminal block has 28 terminals each with an M4 screw outlet for the attachment of external wiring, fitted with 'L' shaped pre-insulated ring tongue terminations.

MLB series Multi-fingered test plugs

The MLB series are inserted into the 2RMLG test socket and is securely retained by means of two knurled screws. The MMLB01 & 02 test plugs incorporate 28 test sockets, each socket accepting a 4mm diameter plug.

MLB series Accessories

The following are supplied with the MMLB01 test plug:
1. 4 short plug links. Each comprised of 50mm of interconnecting cable with a 4mm plug each end.

2. 4 long plug links. Each comprised of 150mm of interconnecting cable with a 4mm plug at each end.

3. 6 spare 4mm plugs. These accept up to 2.5sq. mm flexible insulated cable for test lead purposes.

MMLB02 Single-fingered test plug

The MMLB02 is supplied pre-wired with a length of 1sq. mm twin core flexible insulated cable. For polarity identification one core is black and the other is red.

MMLB 07 CT Shorting

The MMLB 07 is the same unit as the MMLB 01 with the addition of an integral ct shorting contact between terminals 21, 23, 25 & 27 and is coded to be used with the 2RMLG07 Test Socket only.

2RMLB 08 with Shorting Contacts

The MMLB08 is identical to the MMLB01 with shorted contact pairs 1&3, 5&7, 9&11, 15&17 and is coded to be used with the 2RMLG08 Test Socket only.

PRECAUTIONS

BEFORE inserting a Test Plug into a Test Socket carrying current transformer secondary circuits.

ENSURE that the Test Plugs corresponding to the current transformer circuits are short-circuited.

This is to ensure the current transformer secondary circuits are not inadvertently open-circuited during insertion of the last plug.

BEFORE inserting a Test Plug to measure current.

ENSURE that the ammeter is on the correct range and that it is connected to its test leads.

CONNECTIONS

The connections will depend upon the scheme and details must be obtained from the appropriate diagrams. If it is necessary to use the d.c. auxiliary supply during testing, then a test link may be fitted across the sockets in the Test Plug.

Technical Data

High Voltage withstand

Insulation

IEC 255-5: 1977

2RMLG 01/02/07/08
case earth terminal.

5kV rms for 1 minute between all case terminals connected together and the

5kV rms for 1 minute between any contact pair and either adjacent alternate contact pair, provided the intermediate contact pair is not used.

2kV rms for 1 minute between any contact pair and either adjacent contact pair.

2RMLG 01 only

1kV rms for 1 minute between terminals 13 and 14 when the cover is removed (e.g. opening the auxiliary supply or trip circuit).

MMLB 01/07/08

As 2RMLG 01 plus 2kV rms for 1 minute between incoming and outgoing contacts when inserted.

MMLB 02

2kV rms for 1 minute between finger contacts.

MMLB 07

As above with the exception of terminals 21, 23, 25 & 27 which are permanently shorted together

2RMLB08

As above with the exception of terminal pairs 1&3, 5&7, 9&11, 15&17 which are permanently shorted together as pairs

Current withstand

2RMLG 01/02/07/08

All contact circuits rated at 20A continuously or 400A for 1s, ac or dc

MMLB 01

10A continuously or 165A for 1s

MMLB 02

MMLB 07

2RMLB08

Atmospheric environment

Temperature

IEC 255-6: 1988

Storage and transit - 25°C to +70°C

Operating -25°C to +55°C

IEC 68-2-1: 1990

Cold

IEC 68-2-2: 1974

Dry Heat

Humidity

IEC 68-2-3: 1969

56 days at 93% RH and +40°C

Enclosure Protection

IEC 529: 1989

IP50 (dust protected)

Mechanical environment

Vibration

IEC 255-21-1: 1988

Response Class 2

EMC compliance

89/336/EEC

These products have been classified as electromagnetically benign and are therefore excluded from the European Community EMC Directive. (89/336/EEC)

TYPICAL APPLICATION OF THE 2RMLG01 / 2RMLG02 TEST SOCKET AND MMLB01 TEST PLUG

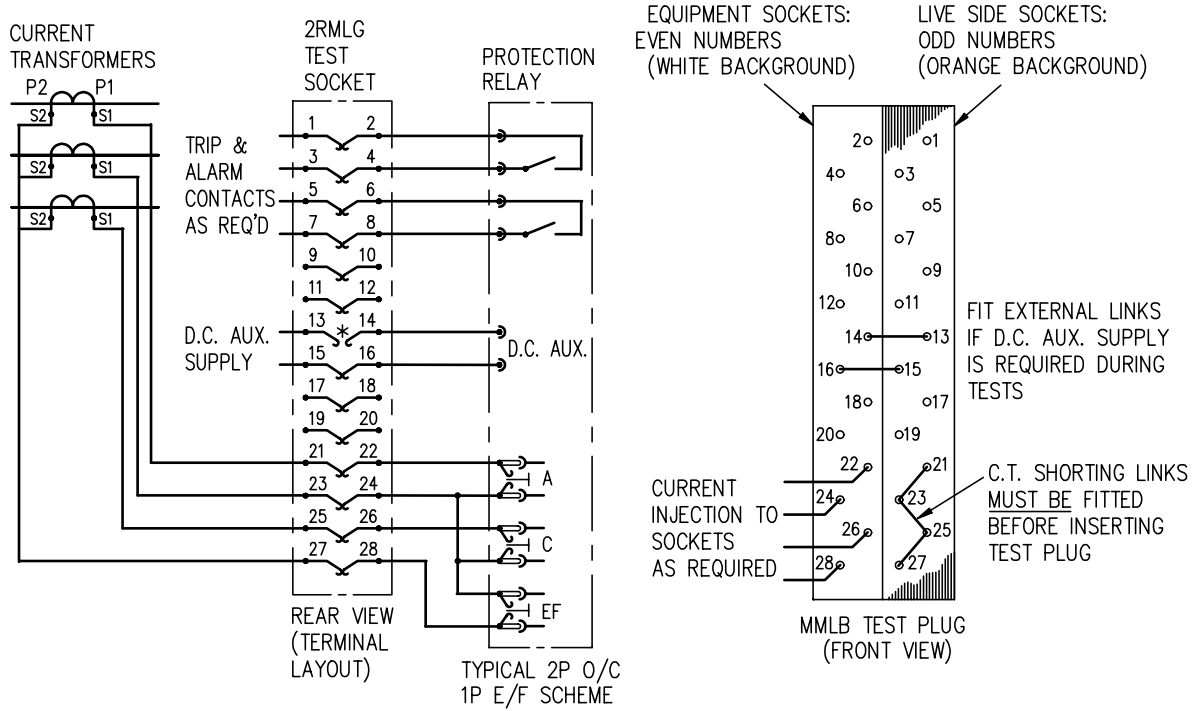

*2RMLG01 13/14 OPEN CCT WHEN COVER REMOVED AND OTHER POSITIONS CONNECTED.
2RMLG02 13/14 CONNECTED AS PER OTHER POSITIONS.

Figure 3

TYPICAL APPLICATION OF THE 2RMLG07 TEST SOCKET AND MMLB07 TEST PLUG

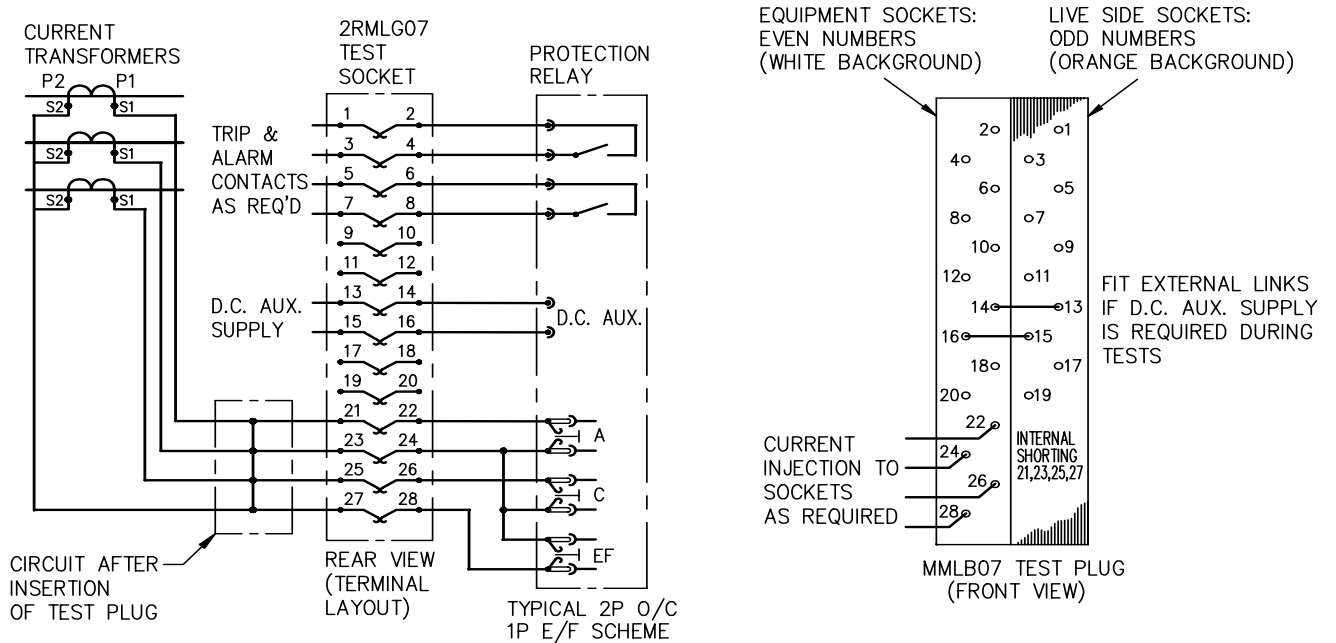
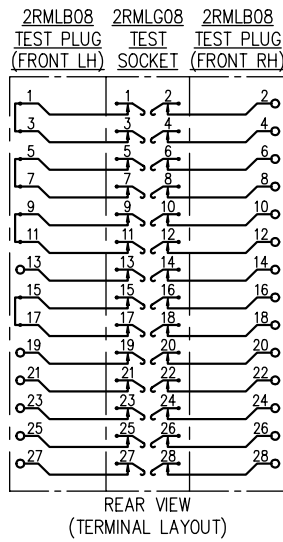

Figure 4

2RMLG08 TEST SOCKET TEST POINTS AND SHORTING ARRANGEMENT WITH 2RMLB08 TEST PLUG INSERTED

[SHORTED TEST POINTS

o TEST INJECTION/MONITOR POINT



EQUIPMENT SOCKETS:
EVEN NUMBERS
(WHITE BACKGROUND)

LIVE SIDE SOCKETS:
ODD NUMBERS
(YELLOW BACKGROUND)

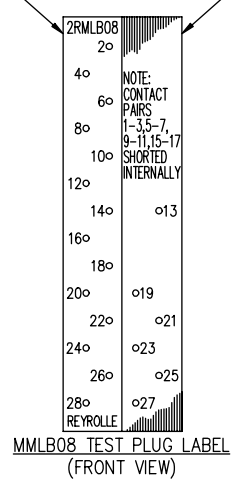
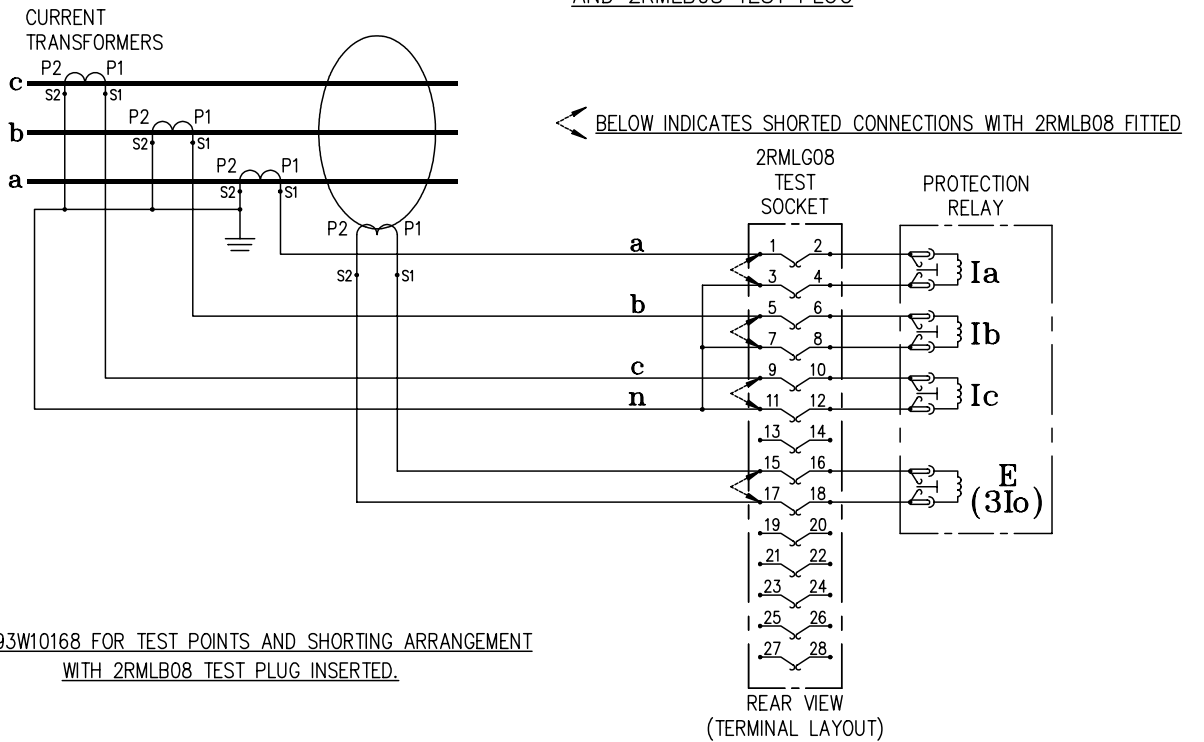

Figure 5

TYPICAL APPLICATION OF THE 2RMLG08 TEST SOCKET AND 2RMLB08 TEST PLUG



SEE 2993W10168 FOR TEST POINTS AND SHORTING ARRANGEMENT WITH 2RMLB08 TEST PLUG INSERTED.

Figure 6

TYPICAL APPLICATION OF THE 2RMLG08 TEST SOCKET
AND 2RMLB08 TEST PLUG

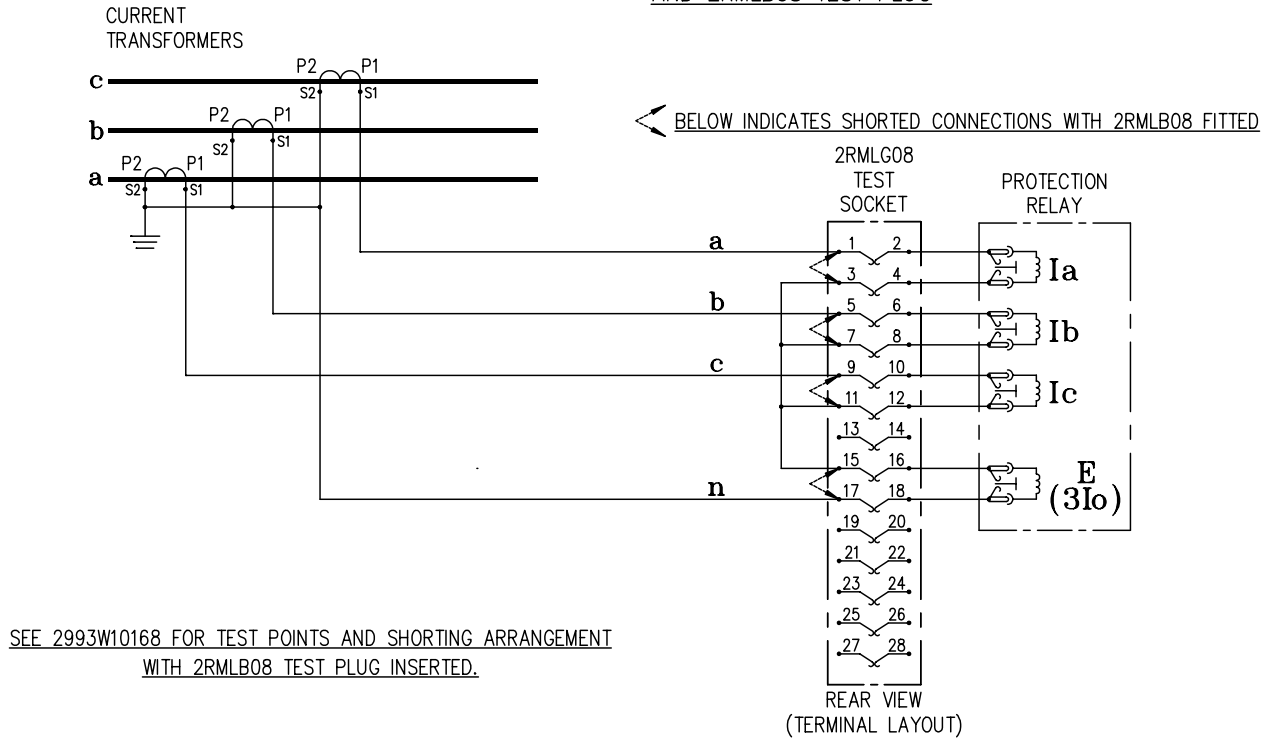

Figure 7

TYPICAL APPLICATION OF THE 2RMLG08 TEST SOCKET
AND 2RMLB08 TEST PLUG

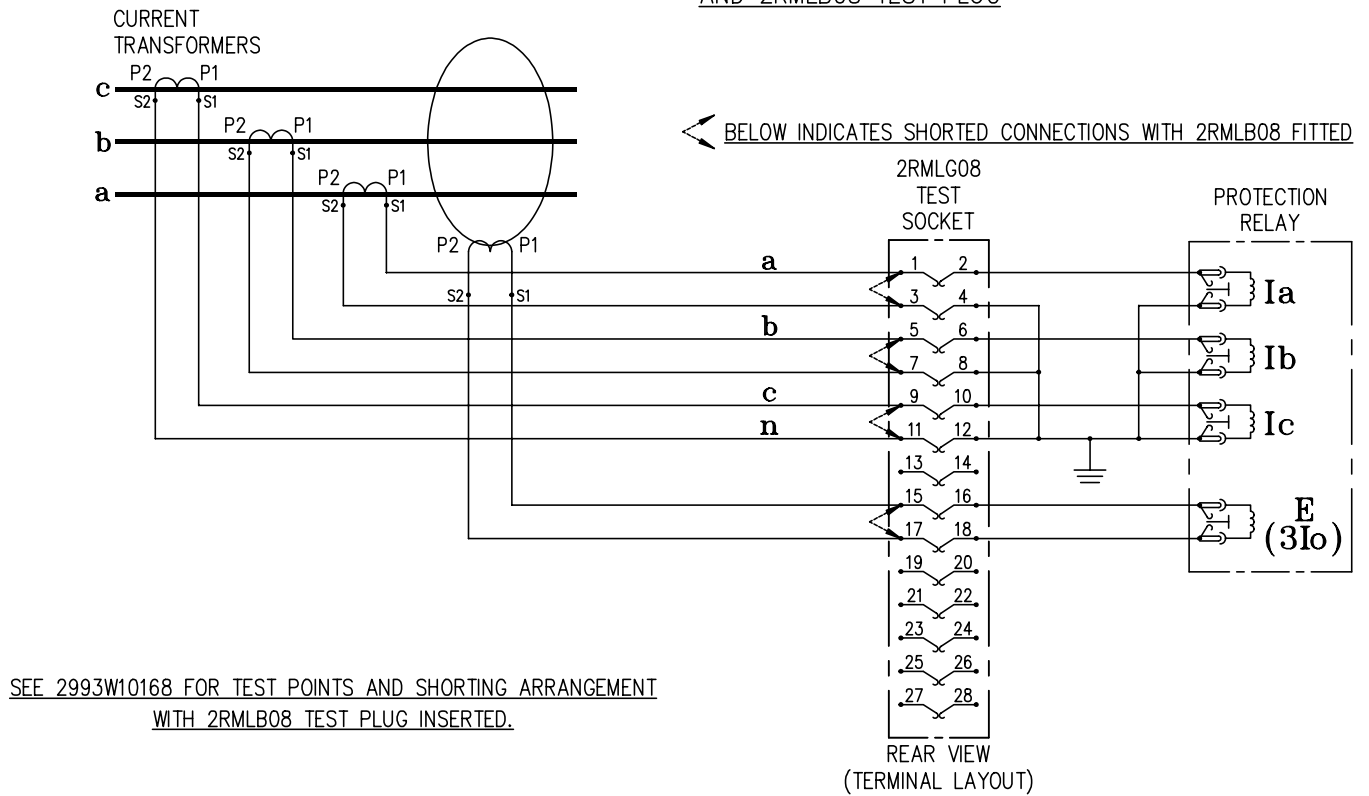
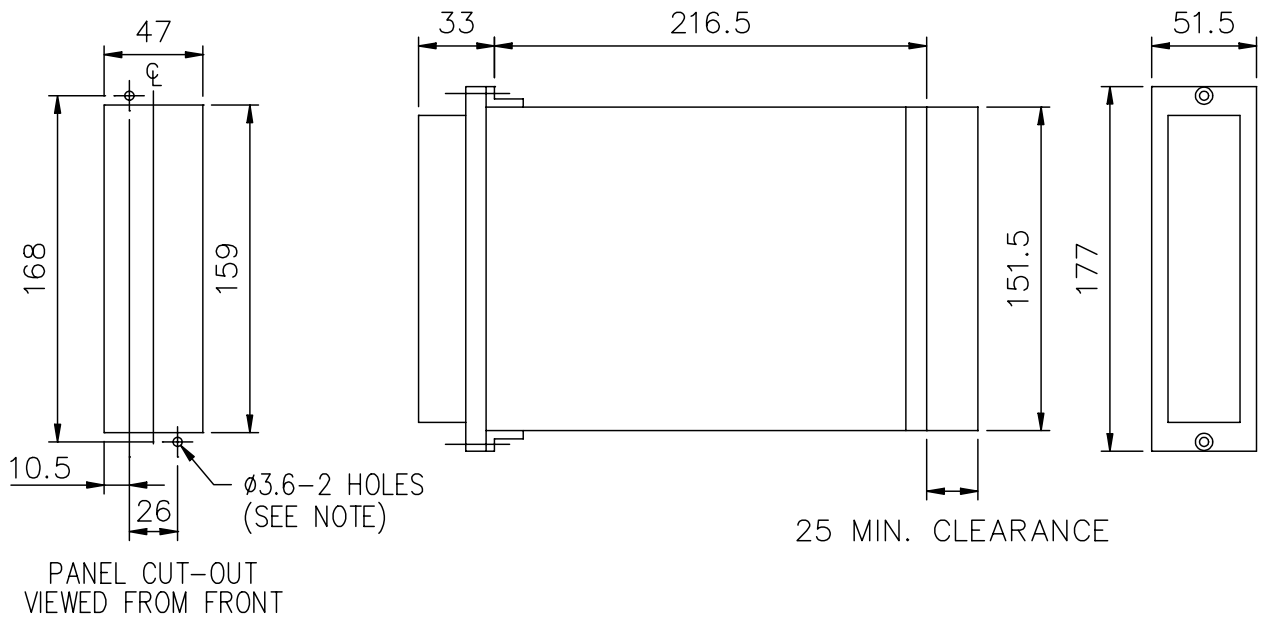

Figure 8

OUTLINE AND DRILLING DRAWING FOR 2RMLG TEST SOCKETS IN EPSILON E2 CASE



NOTE:
THE ø3.6 HOLES ARE FOR M4 THREAD FORMING (TRILOBULAR) SCREWS. THESE ARE SUPPLIED AS STANDARD AND ARE SUITABLE FOR USE IN FERROUS/ALUMINIUM PANELS 1.6mm THICK AND ABOVE. FOR OTHER PANELS, HOLES TO BE M4 CLEARANCE (TYPICALLY ø4.5) AND RELAYS MOUNTED USING M4 MACHINE SCREWS, NUTS AND LOCKWASHERS (SUPPLIED IN PANEL FIXING KIT).

Figure 9